

How to Use VEPP

The Video Encyclopedia of Pool Practice looks daunting at first sight with over 170 different drills and techniques to improve your practice routines. Here are some suggestions on how to start and how to tailor your use of VEPP to your own skill level and current weak points.

View at least briefly Drills 1-14 to become familiar with the training aids used throughout the series and to check on the bedrock fundamentals of your mechanics. Beginners will need to spend a few dozen shots at each drill while more advanced players can skip the on-table practice if they have worked on similar drills in the past. If you have never seen these first drills, try them first as they are the foundation for the rest of the series.

Whenever you are working on a drill at the table, be sure to use one of the log sheets you will find later in this document. Print out several copies. Each page has room to record the date, to diagram any problem or success and to make comments on each of four drills, which is a good number for a routine practice session. There is also room to record a score on each drill which will allow you to keep track of your progress as your game improves. Some drills don't have a built-in score, but try to rate yourself on your mastery on a scale of 1-10. Remember to record the date on the sheet.

You will also find larger diagrams on which you can diagram more exactly shots that you have trouble with in competition or during the more complicated run-out drills. On each diagram be sure to make notes on the details of the problem, such as "backspin OK but not exact enough" so that you will know when you get back to the practice table what you need to work on.

OK, now that you have the basic ideas of VEPP and are ready to record your practice, let's try to find the best drills for you to start with. We can start either with general drills for your present level of play or with specific drills for some skill you are having trouble with. The list of all shots in VEPP is organized by type of shot such as "Draw Shot." If that's your trouble area, go to that section of videos and view it until you get to one that looks like it covers the level of skill you need to work on. Don't make the first one too tough – it's better to build up some confidence and comfort zone.

If you don't have any particular kind of shot that needs work, select some drills according to your skill level as follows:

Fast forward to the drills listed below under your approximate skill level, view them briefly, and pick out four that look like they are useful to you immediately. Spend time on each one and be sure to review the video if the drill doesn't make sense at first. When you feel you have made good progress on a drill, note your score and make any comments that might be helpful the next time you do the drill, such as, "Be sure the tip is taking chalk." You may end up spending a whole practice session on one drill or you may do eight. Either is OK, but practice only as long as you can do it with intensity and attention.

In the descriptions below, PP stands for Progressive Practice which is demonstrated throughout the drills. Remember to mark your progress after each shot and to record your score at the end.

Drills for Beginners

- 15 – PP cut drill 1D
- 23 – lag drill over multiple distances
- 30 – PP stop shot drill 1A (see 28 and 29 for review)
- 34 – PP follow shot drill 1B (see 33 for review)
- 41 – beginner draw drill (see 39 and 40 for review)
- 42 – PP draw drill 1C
- 58 – thin cut-speed control drill
- 67 – english off the short rail drill (see 66 for review)

In addition try some of the easier Rating and Challenge Drills on VEPP V, such as 154 and 159 with the easiest level of each challenge. As your game improves, these challenges, which are a lot like competitive play, are good indicators of your progress.

Drills for Intermediate Players

- 17 – PP cut drill 3D
- 20 – drill from both sides
- 24 – successive touch shot challenge drill
- 26 – pocket speed drill
- 32 – PP stop shot drill 3A
- 36 – PP follow shot drill 3B
- 44 – PP draw drill 3C
- 52 – follow and draw challenge into the side
- 59 – repeated follow challenge drill
- 62 – wagon wheel drill with BIH
- 69 – inside-follow two-rail-position speed control drill
- 70 – outside-draw two-rail-position speed control drill
- 87 – progressive L drill
- 91 and 93 – progressive 9-ball and 8-ball drills – level 1
- 129 and 130 – shallow angle kick drills
- 133 – two-cushion kick-to-corner drill (132 for review)
- 147 – jacked-up-over-obstacle-ball drill

In addition, go over all of 166-177 which show you how to check out a strange table before a match.

Drills for Advanced Players

- 19 – PP cut drill 5D
- 27 – angled pocket speed drill
- 38 – PP follow shot drill 5B
- 46 – PP draw drill 5C
- 49 and 50 – two draw challenge drills
- 53 – run through and stun back drill
- 56 – PP stun shot drill 5A

63 – wagon wheel drill with 1/2-ball hit
64 and 65 to learn how to set up random-position drills
71 and 72 – english wagon wheel off short rail with various angles
91-119 – fixed patterns for 8- and 9-ball – try the ones that are challenging
124 – hide behind target safety drill
131 – line of balls mirror kick drill
140 – perpetual kick challenge drill (review 132-138 if needed)
146 – bank-to-all-pockets challenge drill
151 – progressive distance jump drill
154 – “Playing the Ghost” progressive challenge (8- or 9-ball)
158 – Fargo rating drill
162 – combination and carom drill

In addition go over all of 166-177 which shows you how to check out a strange table before a match. See if you can add your own shots to this sequence based on shots you have had trouble with on unfamiliar equipment.

Good luck with your practice and remember to record it on log sheets.

VEPP Practice Log Sheet

Date _____

Drill # _____ Score _____

Comments:

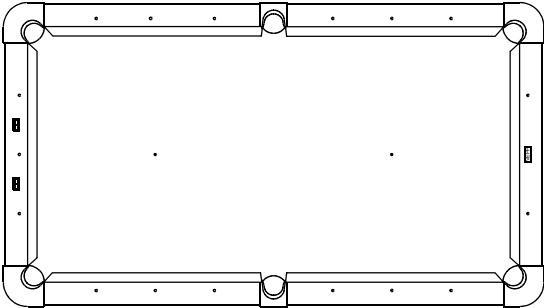

Drill # _____ Score _____

Comments:

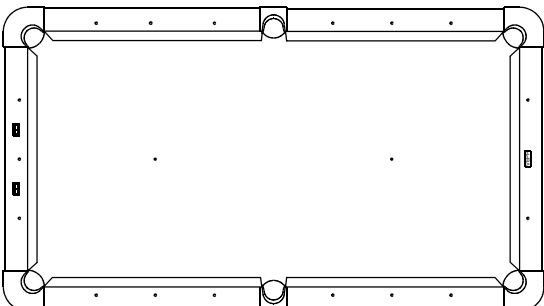

Drill # _____ Score _____

Comments:

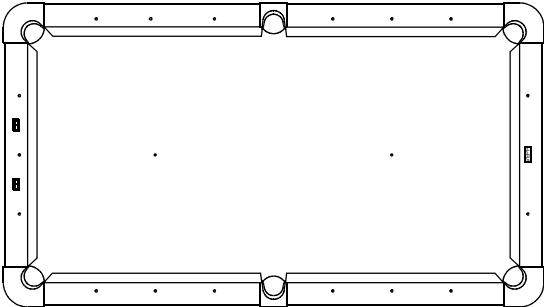

Drill # _____ Score _____

Comments:

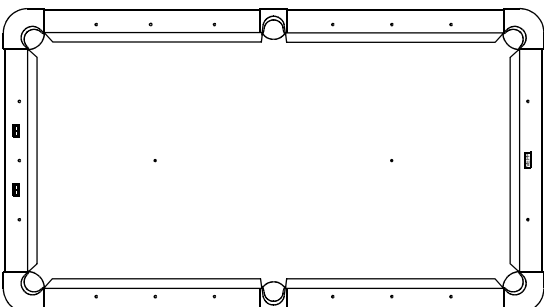

Note: For drills without a formal score, rate your performance on a 0-10 scale relative to your current level.

